

VIBRATION RANGE

VET/VEM

External vibrators



- The clamp counts with a safety strap
- Compatible with different types of formworks
- Clamps are available for VET/VEM 100, 150 and 300 models
- For all kinds of uses: Precast, formwork, hoppers, tables, belts and vibrating screens...

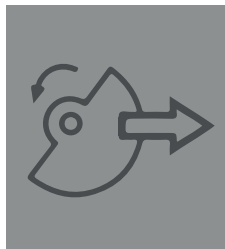
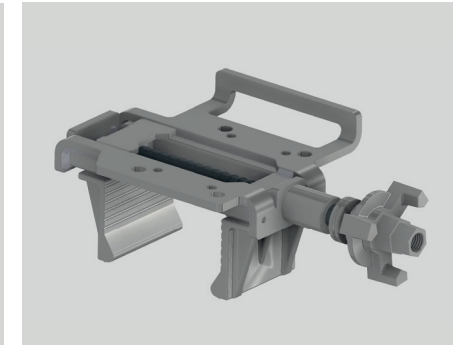

+
Adjustable force

The different models and the eccentric regulation allow adjustment to a wide range of needs.



+
IP65 Protection

Hermetic housing that protects the equipment against external agents such as dust and rain



+
Resistant

Long life high-strength aluminum housing, that performs in adverse working conditions.

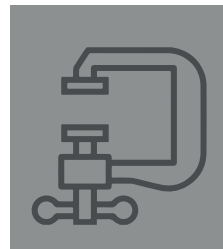

+
Quick coupling

Optional clamps compatible with different formworks, saving time in assembly and operation.

Technical Data

MODEL	Weight (kg)	Centrifugal force (Kg)	Rated current (A)	Oscillations (r.p.m.)	Dimensions CxDxE (mm)	Fixing dimensions AxB (mm)	Cord (m)	Connection	Diameter Ø G (mm)
VET 100	5.1	99	0.2	3000	231x131x159	62-74x106	2	400 V3 ~ 50Hz	9
VET 150	7.3	197	0.35	3000	231x131x159	62-74x106	1	400 V3 ~ 50Hz	9
VET 300	10.5	311	0.52	3000	273x155x175	90x125	1	400 V3 ~ 50Hz	13
VET 600	16.3	516	0.96	3000	362x208x210	120x170	1	400 V3 ~ 50Hz	17
VET 800	21.1	788	1.45	3000	362x208x210	120x170	1	400 V3 ~ 50Hz	17
VET 1600	52.6	1571	2.94	3000	421x229x262	140x190	1	400 V3 ~ 50Hz	17
VEM 100	6.5	99	0.5	3000	231x131x159	62-74x106	2	230 V1 ~ 50Hz	9
VEM 150	7.3	197	1.1	3000	231x131x159	62-74x106	1	230 V1 ~ 50Hz	9
VEM 300	10.5	311	1.15	3000	273x155x177	90x125	1	230 V1 ~ 50Hz	13